

Stove

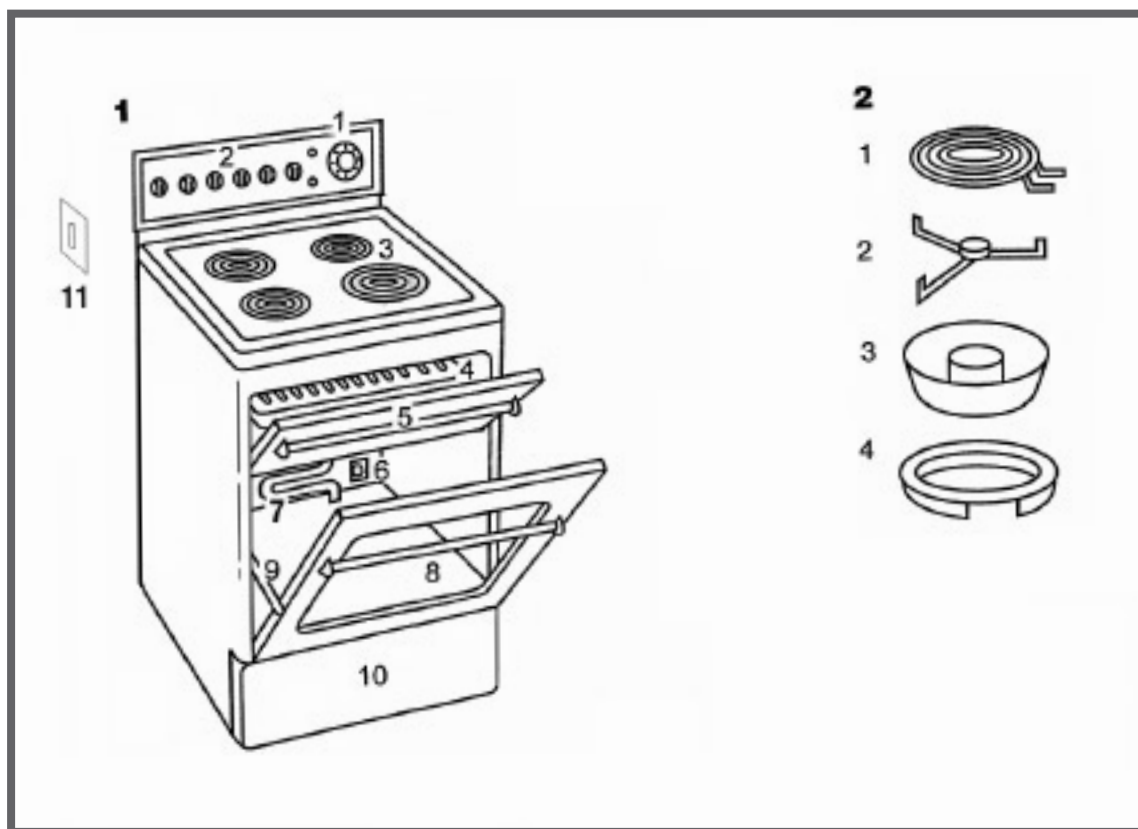

1 Four hot plate electric stove

- 1 Timer
- 2 Control knobs
- 3 Element
- 4 Grill tray
- 5 Grill door
- 6 Oven light
- 7 Element
- 8 Oven door glass
- 9 Oven door hinge
- 10 Kick plate
- 11 Stove on/off switch (on wall)

2 Electric hot plate assembly

- 1 Element
- 2 Element support (trivet/spider)
- 3 Spillage bowl/tray
- 4 Dress ring

Stove

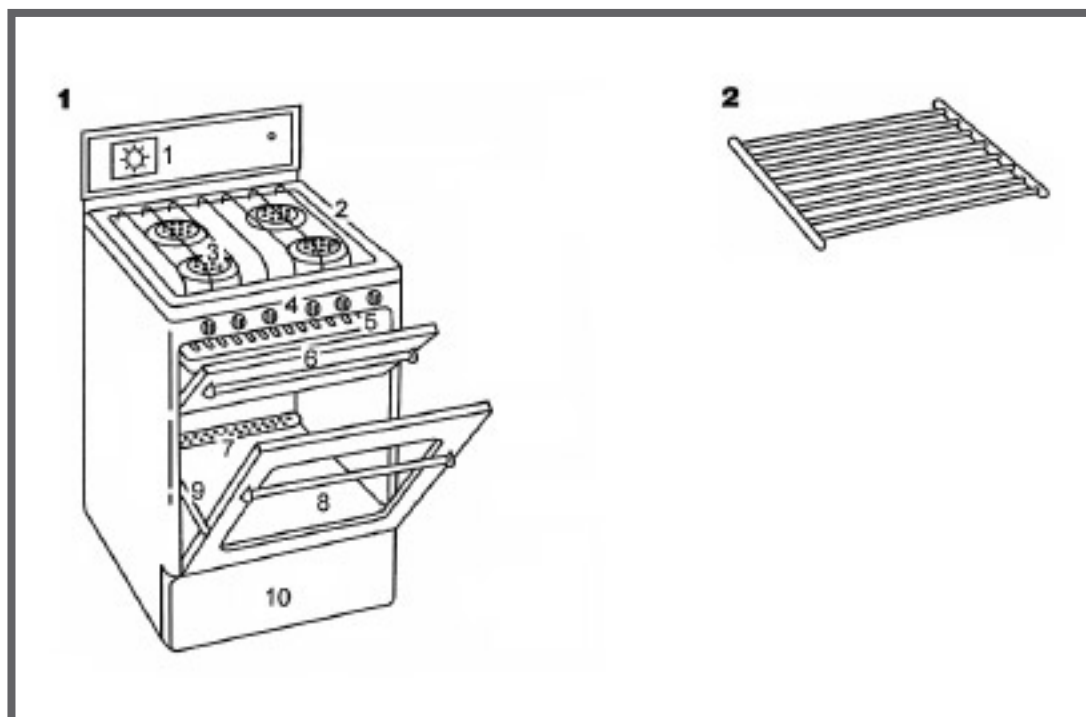

1 Four burner gas stove

- 1 Timer
- 2 One piece trivet
- 3 Burner
- 4 Control knobs
- 5 Grill tray
- 6 Grill door
- 7 Oven burner
- 8 Oven door glass
- 9 Oven door hinge
- 10 Kick plate

2 Oven tray

Stoves

(Electric)

Tenant's Problem	Operator will ask	Probable cause	Suggested remedy	Response Times
Stove not working at all.	Have you checked the circuit board? Have you checked the isolation switch?			Immediate works order will be raised to be attended to within 4 hours.
Unable to turn hotplates off.	Have you checked the circuit board? Have you checked the isolation switch?			Immediate works order will be raised to be attended to within 4 hours.
Hotplate/griller element fails.	Which hotplates have failed (large or small ones)?			Routine works order will be raised to be attended to within 10 working days.
Oven not heating properly.	How long has this been happening for? Do you have an in-the wall oven, or is it part of your stove? Is the rest of your stove working? Are the oven door seals in tact?			Routine works order will be raised to be attended to within 10 working days.
Frame/spillage bowl rusts/corrodes.	How many of these are corroded/rusted?			Routine works order will be raised to be attended to within 10 working days.
Knobs/controls broken.	How many are broken? Which hinges/seals are broken.			Routine works order will be raised to be attended to within 10 working days.
Oven/griller door seals/hinges need adjusting or replacing.	How did this happen? Which hinges/seals are broken?			Routine works order will be raised to be attended to within 10 working days.
Oven light not working.	How long has this been like this? Is it the switch or globe?			Routine works order will be raised to be attended to within 10 working days.
Oven door broken.	What is wrong with the door? Is it off the hinge or has the glass slipped or is the glass broken.			Routine works order will be raised to be attended to within 10 working days.

Stoves

(Gas)

Tenant's Problem	Operator will ask	Probable cause	Suggested remedy	Response Times
Stove not working at all.	Type and make of stove, if known. Are the hotplates or griller working? Have you checked whether your gas bottle is full? Instruct tenant: TURN GAS OFF			Immediate works order will be raised to be attended to within 4 hours. Instruct tenant to: TURN GAS OFF.
Gas jets not lighting.	Which jets are not working?			Urgent works order will be raised to be attended within 2 working days if more than 1 jet not working. If not, routine works order will be raised to be attended to within 10 working days.
Gas leaking from stove.	Instruct tenant to: TURN OFF GAS AT METER. DON NOT USE OPEN FLAME IN HOUSE.			Immediate works order will be raised to be attended to within 4 hours. Instruct tenant to: TURN OFF GAS AT METER. DO NOT USE OPEN FLAME IN HOUSE.
Oven not heating properly.	Is the rest of your stove working. Are the oven door seals intact? Is there a gas smell?			Routine works order will be raised to be attended to within 10 working days. Immediate works order will be raised to be attended to within 4 hours if there is a smell.
Oven light not working.	Globe or switch?			Routine works order will be raised to be attended to within 10 working days.
Oven/griller door hinges/seal broken or need adjusting.	How did this happen? Which hinges/seals are broken?			Routine works order will be raised to be attended to within 10 working days.
Griller not lighting.	Is the rest of the stove working?			Routine works order will be raised to be attended to within 10 working days.
Knobs/controls broken.	How many are broken? Type of stove, if known.			Routine works order will be raised to be attended to within 10 working days.